

CUSTOMER APPROVAL	IF NOT RETURNED TO FGFT BY THE DATE INDICATED BELOW, WE WILL PROCEED WITH FABRICATION AS PER THE DRAWING
SALES SIGNATURE:	
CUSTOMER SIGNATURE:	
DATE:	
RETURN TO FGFT BY:	DATE: 28th FEB 2023
REVIEWED BY:	
REVIEW DATE:	
ACCEPTED AS IS:	<input type="checkbox"/>
ACCEPTED WITH REVISION NOTED:	<input type="checkbox"/>
REVISE AS NOTED AND RE-SUBMIT:	<input type="checkbox"/>

BODY TYPE: EXTRUDED ALUMINUM
TANK SIDE: WET SIDE

DOC. NO. : E018-1 DRAWING TEMPLATE
REV. C 2017-02-05

SPECIFICATION

CHASSIS:
-FREIGHTLINER M2 112, 4X2, SBA REGULAR CAB
-49,000 LB GVWR; 18,000 LB FRONT / 31,000 LB REAR
-DIESEL ENGINE, CUMMINS L9 400EV HP
-AUTOMATIC TRANSMISSION, ALLISON 3000 EVS

PUMP:
-PORTABLE PUMP CET PFP-20hpHND-2D
-THIRD PARTY CERTIFICATION MEETING NFPA 1901-2016 EDITION

PLUMBING AND PIPING: STAINLESS STEEL SCHEDULE 10
- 1 x 3" FEED LINE
- 1 x 4" STORZ EXTERNAL TANK FILL FIREMAN'S FRIEND

TANK:
-1700 IG (2040 USG) POLY

BODY:
-WET SIDE TANKER, EXTRUDED ALUMINUM LOW/LOW
-BODY UNDERCOATING CORASHIELD

EMERGENCY EQUIPMENT/ACCESSORIES:
- LIGHT BAR 60" LED
- SIREN
- 100W SPEAKER
- 2 x FLOOD LIGHTS
- 2 x GRILLE LIGHTS RED/BLUE
- 4 x SIDE UPPER WARNING RED/BLUE
- 4 x SIDE LOWER WARNING LIGHTS RED
- 2 x REAR UPPER WARNING RED/BLUE
- 2 x REAR LOWER WARNING LIGHTS RED
- 4 x SIDE SCENE LIGHTS
- 2 x REAR SCENE LIGHTS
- 6 x GROUND LIGHTS
- AIR CHARGING PROVISION
- BATTERY CHARGING PROVISION
- ANNTENA MOUNT
- (2) 4" x 10' SUCTION HOSE
- (1) 4" BARREL STRAINER KOCHEK

MODEL:
WHELEN FREEDOM IV 60
WHELEN CEN COM
WHELEN SA315P
DTI 010Wx6 LED 12V
WHELEN 600
WHELEN M6
WHELEN 600
WHELEN M6
WHELEN 600
WHELEN M9LZC
WHELEN M6LZC
LUMA BAR H20-12"
KUSSMAUL AUTO CHARGE 1200 PLC

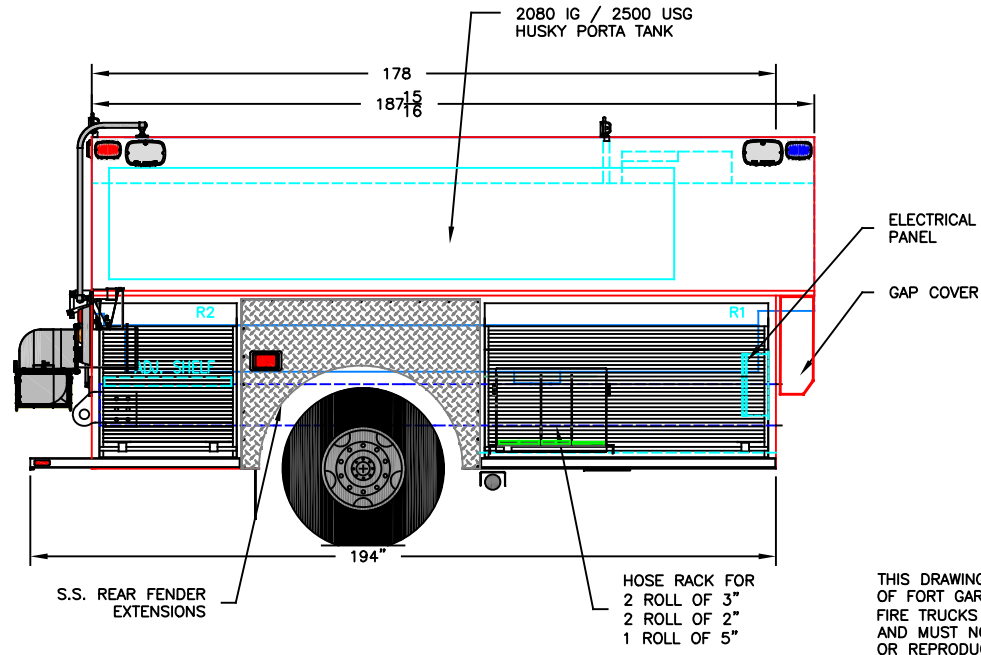
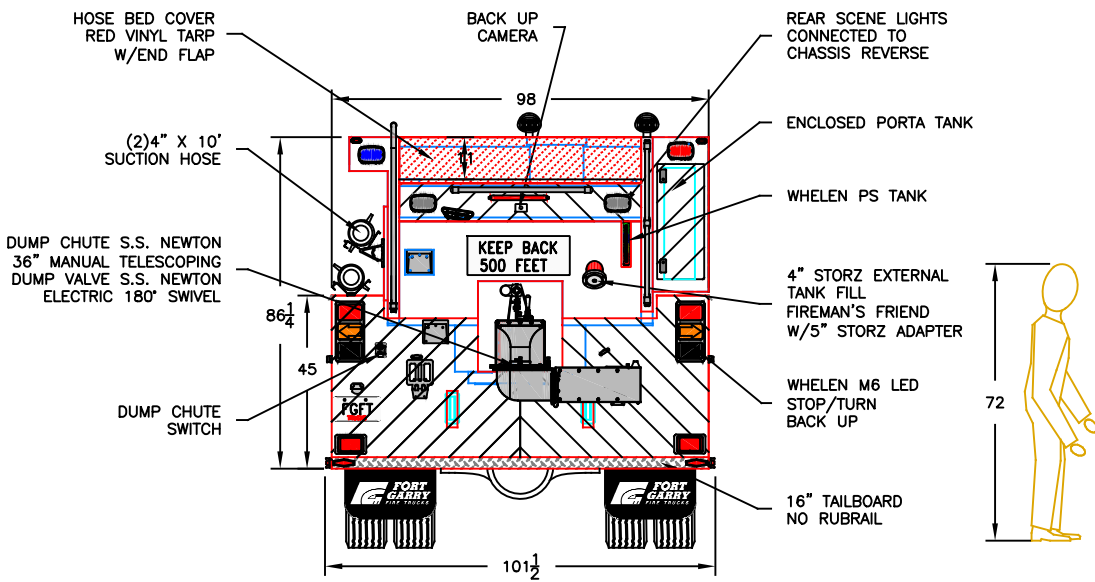
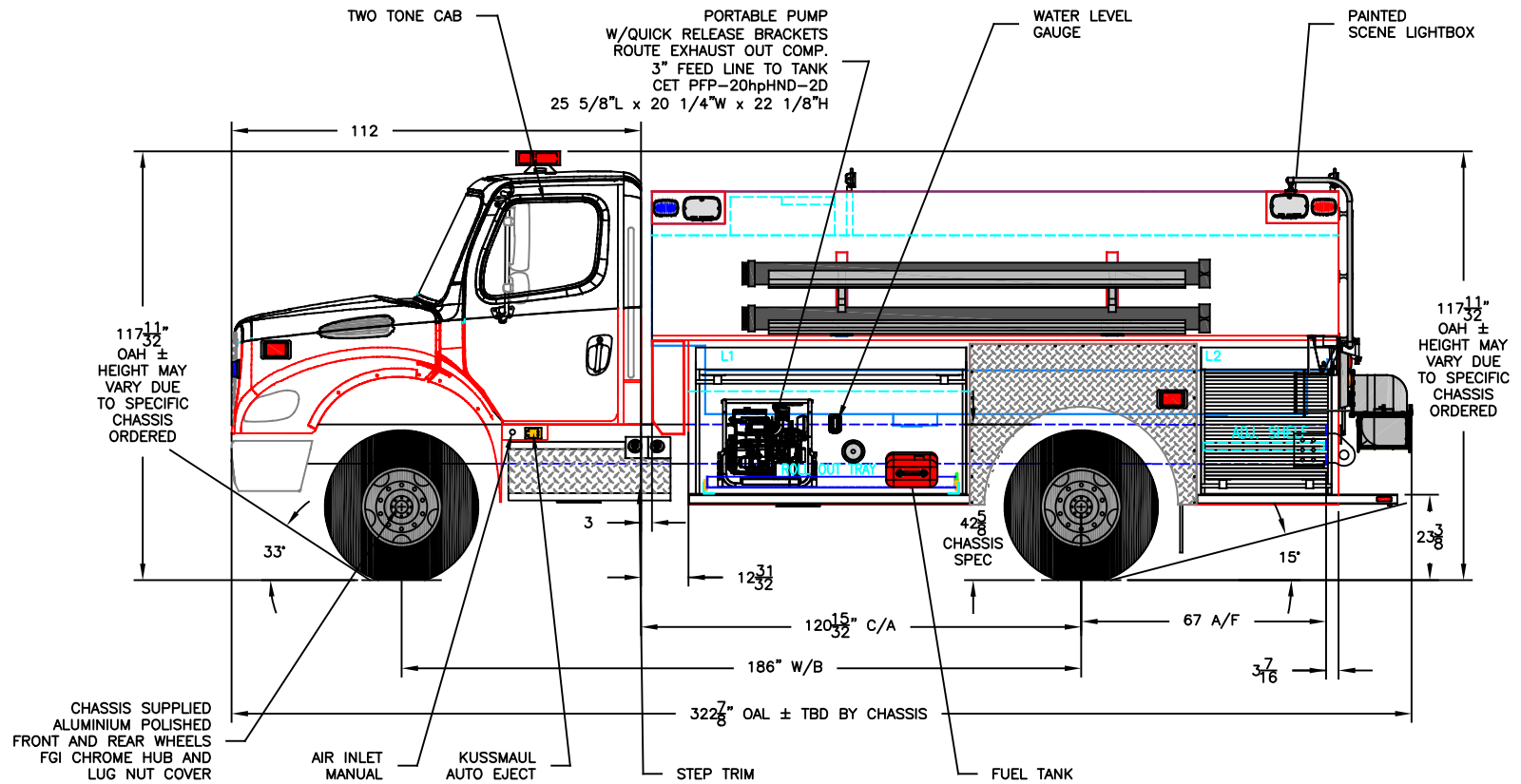
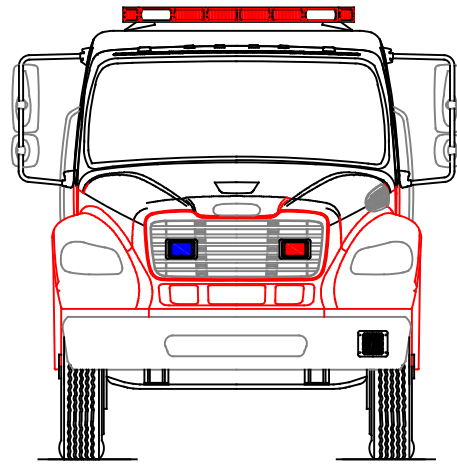

THIS DRAWING IS PROPERTY OF FORT GARRY FIRE TRUCKS LTD (FGFT) AND MUST NOT BE COPIED OR REPRODUCED IN WHOLE OR IN PART, BY ANY METHOD WHATSOEVER, WITHOUT AUTHORIZATION OF FGFT.

COMPT.	COMPARTMENT FRAME DIMENSIONS
L1	74W x 40H x 13.5/26D
L2	36W x 40H x 13.5/26D
R1	74W x 40H x 13.5/26D
R2	36W x 40H x 13.5/26D

1. THE DRAWING IS FOR REFERENCE PURPOSE, ONLY. THE DRAWING MAY OR MAY NOT SHOW ALL ITEMS AS DESCRIBED IN THE WRITTEN DETAILED SPECIFICATION.
2. INCLUSION OF AN ITEM ON THE DRAWING DOES NOT CONSTITUTE INCLUSION OF THAT ITEM WITH THE FINAL DELIVERY OF THE UNIT. SPECIFICATION SHALL BE FINAL AUTHORITY TO BE DETERMINED WHAT IS SUPPLIED ON THE APPARATUS.
3. THE EFFECTIVE DOOR OPENING FOR ROLLUP DOORS WILL BE REDUCED APPROX. 10" IN HEIGHT, 2" IN DEPTH AND 2" IN WIDTH FROM SHOWN FRAME OPENINGS AND 2" IN HEIGHT, 3" IN DEPTH AND UP TO 4" IN WIDTH FOR PAN DOORS. DIMENSIONS TOLERANCE ± 1/4"
4. PUMP RATING AND TANK CAPACITY ARE SHOWN AS NOMINAL VALUES. THE ACTUAL VALUES MAY VARY.
5. CHASSIS GVWR SHOWN IS THE MINIMUM REQUIRED FOR STANDARD BODY DEPENDING OF OPTIONS, GVWR MAY NEED TO BE INCREASED.
6. COMMERCIAL OEM CAB STEPS MAY NOT MEET ULC STANDARD. SELECT CUSTOM STEPS WHEN REQUIRED.
7. OVERALL HEIGHT IS IN LOADED CONDITION, UNLOADED HEIGHT MAY BE 4" ABOVE HEIGHT SHOWN. AFTER TRUCK IS COMPLETED ADDITIONAL STEPS MAY BE REQUIRED TO MEET THE STANDARD.
8. DIMENSIONS SHOWN ARE APPROXIMATE AND ARE SUBJECT TO CHANGE AS MAY BE FOUND NECESSARY DURING DESIGN. DO NOT SCALE DRAWING.
9. MINOR DETAILS AND REFLECTIVE STRIPING ARE NOT SHOWN.

D	REVISED CUSTOMER SIGN OFF DWG	SP	22 FEB 2023
C	REVISED CUSTOMER SIGN OFF DWG	SP	13 FEB 2023
B	CUSTOMER SIGN OFF DRAWING	SP	28 DEC 2022
A	CRM DRAWING	SP	25 NOV 2022
REV	DESCRIPTION OF CHANGE	BY	DATE

FORT GARRY
FIRE TRUCKS
WWW.FGFT.COM
WINNIPEG, MANITOBA, CANADA 1-800-565-3473

DESCRIPTION:	EAST CANADA CREEK F.D.	
SCALE:	DWG. BY:	CHK. BY:
1:50	SP	

MODEL:	SHEET:
AT17PP	1 OF 1
DATE:	DWG. NO. :
07 JUN 2022	J0419